

Adaptive Analog Nonlinear Algorithms and Circuits for Improving Signal Quality in the Presence of Technogenic Interference

Alexei V. Nikitin
Avatekh Inc
Lawrence, Kansas 66044-5498, USA
E-mail: avn@avatekh.com

Ruslan L. Davidchack
Department of Mathematics
University of Leicester
Leicester, LE1 7RH, UK
E-mail: rld8@leicester.ac.uk

Tim J. Sobering
Electronics Design Laboratory
Kansas State University
Manhattan, Kansas 66506-0400, USA
E-mail: tjsober@pobox.com

Abstract—We introduce algorithms and conceptual circuits for Nonlinear Differential Limiters (NDLs), and outline a methodology for their use to mitigate in-band noise and interference, especially that of technogenic (man-made) origin, affecting various real, complex, and/or vector signals of interest, and limiting the performance of the affected devices and services. At any given frequency, a linear filter affects both the noise and the signal of interest proportionally, and when a linear filter is used to suppress the interference outside of the passband of interest, the resulting signal quality is invariant to the type of the amplitude distribution of the interfering signal, as long as the total power and the spectral composition of the interference remain unchanged. Such a linear filter can be converted into an NDL by introducing an appropriately chosen feedback-based nonlinearity into the response of the filter, and the NDL may reduce the spectral density of particular types of interferences in the signal passband without significantly affecting the signal of interest. As a result, the signal quality can be improved in excess of that achievable by the respective linear filter. The behavior of an NDL filter and its degree of nonlinearity is controlled by a single parameter in a manner that enables significantly better overall suppression of the noise compared to the respective linear filter, especially when the noise contains components of technogenic origin. Adaptive configurations of NDLs are similarly controlled by a single parameter, and are suitable for improving quality of non-stationary signals under time-varying noise conditions. NDLs are designed to be fully compatible with existing linear devices and systems, and to be used as an enhancement, or as a low-cost alternative, to the state-of-art interference mitigation methods.

Keywords—analog signal processing; electromagnetic interference; in-band noise; man-made interference; non-Gaussian noise; nonlinear differential limiters; nonlinear filtering; signal quality; technogenic interference.

I. INTRODUCTION

Technogenic (man-made) noise, unintentional as well as intentional, is a ubiquitous and rapidly growing source of interference with various electronic devices, systems, and services [1], harmfully affecting their physical, commercial, and operational properties. This noise may originate from various sources such as mutual interference of multiple devices combined in a system (for example, a smartphone equipped

with WiFi, Bluetooth, GPS, and many other devices), electrical equipment and electronics in a car, home and office, dense urban and industrial environments, increasingly crowded wireless spectrum, and intentional jamming.

The sources of technogenic noise can be also classified as circuit noise or as interference from extraneous sources, such as conductive electromagnetic interference and radio frequency interference, intelligent (co-channel, adjacent-channel interference) as well as non-intelligent (commercial electronic devices, powerlines, and platform (clocks, amplifiers, co-located transceivers, buses, switching power supplies)) sources, and self-interference (multipath). The multitude of these sources, often combined with their physical proximity and a wide range of possible transmit and receive powers, creates a variety of challenging interference scenarios. Existing empirical evidence [1]–[4] and its theoretical support [5]–[9] show that such interference often manifests itself as non-Gaussian and, in particular, *impulsive* noise, which in many instances may dominate over the thermal noise [2]–[5], [9].

Examples of systems and services harmfully affected by technogenic noise include various communication and navigation devices and services [2], [4], [5], [7], [8], wireless internet [6], coherent imaging systems such as synthetic aperture radar [10], cable, DSL, and power line communications [11], [12], wireless sensor networks [13], and many others. A particular impulsive noise problem also arises when devices based on the ultra-wideband (UWB) technology interfere with narrowband communication systems such as WLAN [14] or CDMA-based cellular systems [15]. A UWB device is seen by a narrowband receiver as a source of impulsive noise, which degrades the performance of the receiver and increases its power consumption [15].

Technogenic noise comes in a great variety of forms, but it will typically have a temporal and/or amplitude structure which distinguishes it from the natural (e.g. thermal) noise. It will typically also have non-Gaussian amplitude distribution. These features of technogenic noise provide an opportunity for its mitigation by nonlinear filters, especially for the in-band noise, where linear filters that are typically deployed in the

communication receiver have very little or no effect. Indeed, at any given frequency, a linear filter affects both the noise and the signal of interest proportionally. When a linear filter is used to suppress the interference outside of the passband of interest, the resulting signal quality is affected by the total power and spectral composition, but not by the type of the amplitude distribution of the interfering signal. On the other hand, the spectral density of a non-Gaussian interference in the signal passband can be reduced, without significantly affecting the signal of interest, by introducing an appropriately chosen feedback-based nonlinearity into the response of the linear filter.

In particular, impulsive interference that is characterized by frequent occurrence of outliers can be effectively mitigated by the Nonlinear Differential Limiters (NDLs) described in [9], [16], [17] and in this paper. An NDL can be configured to behave linearly when the input signal does not contain outliers, but when the outliers are encountered, the nonlinear response of the NDL limits the magnitude of the respective outliers in the output signal. As a result, the signal quality is improved in excess of that achievable by the respective linear filter, increasing the capacity of a communications channel. Even if the interference appears non-impulsive, the non-Gaussian nature of its amplitude distribution enables simple analog pre-processing which can increase its *peakedness* and thus increase the effectiveness of the NDL mitigation.

Another important consideration is the dynamic non-stationary nature of technogenic noise. When the frequency bands, modulation/communication protocol schemes, power levels, and other parameters of the transmitter and the receiver are stationary and well defined, the interference scenarios may be analyzed in great detail. Then the system may be carefully engineered (albeit at a cost) to minimize the interference.¹ It is far more challenging to quantify and address the multitude of complicated interference scenarios in non-stationary communication systems such as, for example, software-defined radio (SDR)-based and cognitive *ad hoc* networks comprising mobile transmitters and receivers, each acting as a local router communicating with a mobile *ad hoc* network (MANET) access point [18]. In this scenario, the transmitter positions, powers, and/or spectrum allocations may vary dynamically. In multiple access schemes, the interference is affected by the varying distribution and arrangement of transmitting nodes. In addition, with MANETs, the fading distribution also varies dynamically, and the path loss distribution is unbounded. With spectrum-aware MANETs, frequency allocations could also depend on various criteria, e.g. whitespace and the customer quality of service goals. This is a very challenging situation which requires the interference mitigation tools to adapt to the dynamically changing interference. Following the dynamic nature of the *ad hoc* networks, where the networks themselves

¹For example, the out-of-band (OOB) emissions of a transmitter may be greatly reduced by employing a high quality bandpass filter in the antenna circuit of the transmitter. Such an additional filter, however, may negatively affect other properties of a system, for example, by increasing its cost and power consumption (due to the insertion loss of the filter).

are scalable and adaptive, and include spectrum sensing and dynamic re-configuration of the network parameters, the interference mitigation tools are needed to be scalable and adaptive to the dynamically changing interference. The Adaptive NDLs (ANDLs) [17] have been developed to address this challenge.

The rest of the paper is organized as follows. In Section II, we discuss the differences in the amplitude distributions between thermal noise and technogenic signals, and provide an illustrative mechanism leading to non-Gaussian nature of technogenic noise. In Section III, we introduce NDLs designed for mitigation of impulsive interference, and in Section IV we discuss their use for mitigation of other types of technogenic noise. In Section V, we introduce an adaptive NDL for non-stationary signals and/or time-varying noise conditions. In Section VI, we illustrate the ANDL performance for a model signal+noise mixture, and in Section VII we provide examples of circuit topologies for the main ANDL sub-circuits. Finally, in Section VIII we provide some concluding remarks.

II. DISTRIBUTIONAL DIFFERENCES BETWEEN THERMAL NOISE AND TECHNOGENIC SIGNALS

A technogenic (man-made) signal is typically, by design, distinguishable from a purely random signal such as thermal noise, unless the man-made signal is intentionally made to mimic such a random signal. This distinction can be made in various signal characteristics in time or frequency domains, or in terms of the signal amplitude distribution and/or density. Examples of technogenic signals include simple wave forms such as sine, square, and triangle waves, or communication signals that can be characterized by constellation (scatter) diagrams representative of their densities in the complex plane. The amplitude distribution of a technogenic signal is typically non-Gaussian, unless it is observed in a sufficiently narrow frequency band [4], [9], [16], [17].

Unless the signal is a pure sine wave, its time-domain appearance and frequency-domain characteristics are modifiable by linear filtering. However, if the input to a linear filter is purely Gaussian (e.g. thermal), the amplitude distribution of the output remains Gaussian regardless the type and properties of a linear filter, and regardless whether the signal is a real, complex, or vector signal [17]. This is illustrated in Fig. 1, which shows that filtering a real Gaussian input signal with an RC integrator/differentiator or a bandpass filter does not affect the amplitude distribution, while the time-domain (and/or frequency domain) appearance of the output changes.

On the other hand, the amplitude distribution of a non-Gaussian signal is generally modifiable by linear filtering, as illustrated in Fig. 2 for a clock-like input signal (approximate square wave). In this figure, the amplitude densities of the input and output signals (red shading) are shown in comparison with Gaussian densities of the same variance (green shading). An additional practical example is given in Section IV.

For the subsequent discussion of the differences between various distributions in relation to mitigation of technogenic interference, a useful quantifier for such differences is a measure of peakedness of a distribution relative to a Gaussian

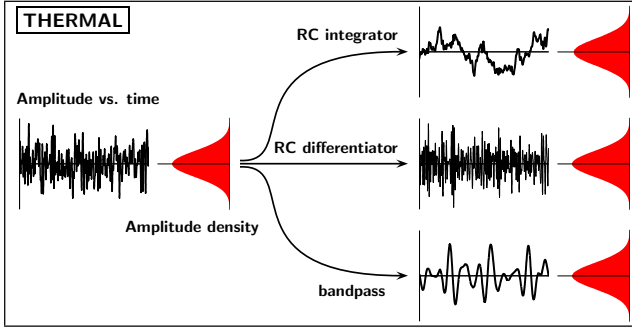

Fig. 1. Effect of linear filtering on amplitude distribution of thermal signal.

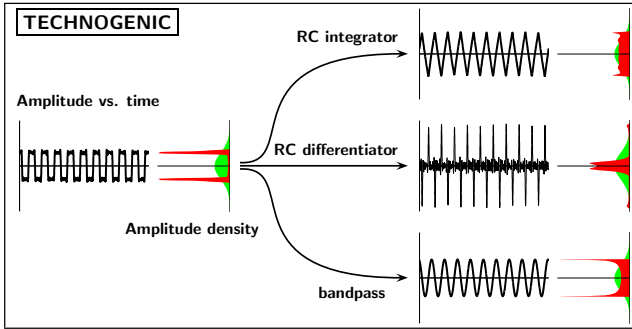

Fig. 2. Effect of linear filtering on amplitude distribution of technogenic signal.

distribution. In terms of the amplitude distribution of a signal, a higher peakedness compared to a Gaussian distribution (super-Gaussian) normally translates into “heavier tails” than those of a Gaussian distribution. In the time domain, high peakedness implies more frequent occurrence of outliers, that is, an impulsive signal.

Various measures of peakedness can be constructed. Examples include the *excess-to-average power ratio* described in [7], [8], measures based on tests of normality [16], [17], or those based on the classical definition of *kurtosis* [19].

Based on the definition of kurtosis in [19], the peakedness of a real signal $x(t)$ can be measured in units of “decibels relative to Gaussian” (dBG) (i.e. in relation to the kurtosis of the Gaussian (aka normal) distribution) as follows [16], [17]:

$$K_{\text{dBG}}(x) = 10 \lg \left[\frac{\langle (x - \langle x \rangle)^4 \rangle}{3 \langle (x - \langle x \rangle)^2 \rangle^2} \right], \quad (1)$$

where the angular brackets denote the time averaging. According to this definition, a Gaussian distribution has zero dBG peakedness, while sub-Gaussian and super-Gaussian distributions have negative and positive dBG peakedness, respectively. For example, in Fig. 2 the input signal and the outputs of the RC integrator and the bandpass filter are sub-Gaussian signals (the peakedness of an ideal square, triangle, and sine wave is approximately -4.77 , -2.22 , and -3.01 dBG, respectively), while the output of the RC differentiator is super-Gaussian (impulsive).

It is important to notice that, while positive dBG peakedness indicates the presence of an impulsive component in a signal, negative or zero dBG peakedness does not necessarily exclude

the presence of such an impulsive component. As follows from the linearity property of kurtosis, a mixture of super-Gaussian (positive kurtosis) and sub-Gaussian (negative kurtosis) signals can have any value of kurtosis.

Extending the definition of kurtosis to complex variables [20], the peakedness of the complex-valued signal $z(t)$ can be computed as [17]

$$K_{\text{dBG}}(z) = 10 \lg \left(\frac{\langle |z|^4 \rangle - |\langle zz \rangle|^2}{2 \langle |z|^2 \rangle^2} \right). \quad (2)$$

Just like for real-valued signals, K_{dBG} vanishes for a Gaussian distribution and attains positive and negative values for super- and sub-Gaussian distributions, respectively.

A. Origins of Non-Gaussian Nature of Technogenic Noise

A simplified explanation of non-Gaussian (and often impulsive) nature of a technogenic noise produced by digital electronics and communication systems can be as follows. An idealized discrete-level (digital) signal can be viewed as a linear combination of Heaviside unit step functions [21]. Since the derivative of the Heaviside unit step function is the Dirac δ -function [22], the derivative of an idealized digital signal is a linear combination of Dirac δ -functions, which is a limitlessly impulsive signal with zero interquartile range and infinite peakedness. The derivative of a “real” (i.e. no longer idealized) digital signal can thus be viewed as a convolution of a linear combination of Dirac δ -functions with a continuous kernel. If the kernel is sufficiently narrow (for example, the bandwidth is sufficiently large), the resulting signal will appear as an impulse train protruding from a continuous background signal. Thus impulsive interference occurs “naturally” in digital electronics as “ di/dt ” (inductive) noise or as the result of coupling (for example, capacitive) between various circuit components and traces, leading to the so-called “platform noise” [3]. Additional illustrative mechanisms of impulsive interference in digital communication systems can be found in [7]–[9].

III. NONLINEAR DIFFERENTIAL LIMITERS (NDLs) FOR MITIGATION OF IMPULSIVE INTERFERENCE

As outlined in [4], [7]–[9] and discussed in more detail in [16], [17], a technogenic (man-made) interference is likely to appear impulsive under a wide range of conditions, especially if observed at a sufficiently wide bandwidth. In the time domain, impulsive interference is characterized by a relatively high occurrence of *outliers*, that is, by the presence of a relatively short duration, high amplitude transients. In this section, we provide an introduction to Nonlinear Differential Limiters (NDLs) designed for mitigation of such interference. Additional descriptions of the NDLs, with detailed analysis and examples of various NDL configurations, non-adaptive as well as adaptive, can be found in [9], [16], [17].

Without loss of generality, we can assume that the signal spectrum occupies a finite range approximately below some frequency B_b . Then we can apply a lowpass filter with a cutoff frequency approximately equal to B_b to suppress the interference outside of this passband. For example, we can

apply a second order analog lowpass filter described by the differential equation

$$\zeta(t) = z(t) - \tau \dot{\zeta}(t) - (\tau Q)^2 \ddot{\zeta}(t), \quad (3)$$

where $z(t)$ and $\zeta(t)$ are the input and the output signals, respectively (which can be real-, complex-, or vector-valued), τ is the *time parameter* of the filter, $\tau \approx 1/(2\pi Q B_b)$, Q is the quality factor, and the dot and the double dot denote the first and the second time derivatives, respectively. We can further assume that the quality factor Q is sufficiently small (for example, $Q \lesssim 1/\sqrt{2}$) so that the lowpass filter itself does not generate high amplitude transients in the output signal.

A bandwidth of a lowpass filter can be defined as an integral over all frequencies (from zero to infinity) of a product of the frequency with the filter frequency response, divided by an integral of the filter frequency response over all frequencies. Then, for a second order lowpass filter, the reduction of the cutoff frequency and/or the reduction of the quality factor both result in the reduction of the filter bandwidth, as the latter is a monotonically increasing function of the cutoff frequency, and a monotonically increasing function of the quality factor.

Assuming that the time parameter τ and the quality factor Q in (3) are constants (that is, the filter is linear and time-invariant), it is clear that when the input signal $z(t)$ is increased by a factor of K , the output $\zeta(t)$ is also increased by the same factor, as is the difference between the input and the output. For convenience, we will call the difference between the input and the output $z(t) - \zeta(t)$ the *difference signal*. A transient outlier in the input signal will result in a transient outlier in the difference signal of the filter, and an increase in the input outlier by a factor of K will result in the same factor increase in the respective outlier of the difference signal. If a significant portion of the frequency content of the input outlier is within the passband of the linear filter, the output will typically also contain an outlier corresponding to the input outlier, and the amplitudes of the input and the output outliers will be proportional to each other. Thus reduction of the output outliers, while preserving the relationship between the input and the output for the portions of the signal not containing the outliers, can be accomplished by dynamically reducing the bandwidth of the lowpass filter when an outlier in the difference signal is encountered.

Such reduction of the bandwidth can be achieved based on the magnitude (e.g. the absolute value) of the difference signal, for example, by making either or both the filter cutoff frequency and its quality factor a monotonically decreasing function of the magnitude of the difference signal when this magnitude exceeds some *resolution parameter* α . A filter comprising such proper dynamic modification of the filter bandwidth based on the magnitude of the difference signal is a Nonlinear Differential Limiter (NDL) [9], [16], [17].

It is important to note that the “bandwidth” of an NDL is by no means its “true,” or “instantaneous” bandwidth, as defining such a bandwidth for a nonlinear filter would be meaningless. Rather, this bandwidth is a convenient computational proxy that should be understood as a bandwidth of a respective

linear filter with the filter coefficients (e.g. τ and Q in (3)) equal to the instantaneous values of the NDL filter parameters. With such clarification of the NDL bandwidth in mind, Fig. 3 provides an illustrative block diagram of an NDL.

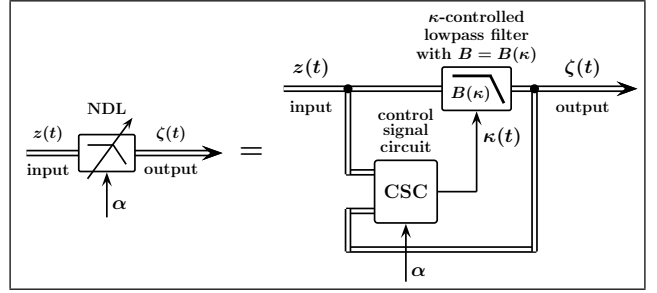

Fig. 3. Block diagram of Nonlinear Differential Limiter.

In Fig. 3, the bandwidth $B = B(\kappa)$ of the lowpass filter is controlled (e.g. by controlling the values of the electronic components of the filter) by the external control signal $\kappa(t)$ produced by the Control Signal Circuit (CSC). The CSC compares an instantaneous magnitude of the difference signal with the resolution parameter α and provides the control signal $\kappa(t)$ that reduces the bandwidth of the κ -controlled lowpass filter when an outlier is encountered (e.g. when this magnitude exceeds the resolution parameter).

A particular dependence of the NDL parameters on the difference signal can be specified in a variety of ways discussed in more detail in [9], [16], [17]. In the examples presented in this paper, we use a second order NDL given by (3) where the quality factor Q is a constant, and the time parameter τ relates to the resolution parameter α and the absolute value of the difference signal $|z(t) - \zeta(t)|$ as

$$\tau(|z - \zeta|) = \tau_0 \times \begin{cases} 1 & \text{for } |z - \zeta| \leq \alpha \\ \left(\frac{|z - \zeta|}{\alpha}\right)^2 & \text{otherwise} \end{cases}, \quad (4)$$

where $\tau_0 = \text{const}$ is the initial (minimal) time parameter.

It should be easily seen from (4) that in the limit of a large resolution parameter, $\alpha \rightarrow \infty$, an NDL becomes equivalent to the respective linear filter with $\tau = \tau_0 = \text{const}$. This is an important property of the NDLs, enabling their full compatibility with linear systems. At the same time, when the noise affecting the signal of interest contains impulsive outliers, the signal quality (e.g. as characterized by a signal-to-noise ratio (SNR), a throughput capacity of a communication channel, or other measures of signal quality) exhibits a global maximum at a certain finite value of the resolution parameter $\alpha = \alpha_{\text{max}}$. This property of an NDL enables its use for improving the signal quality in excess of that achievable by the respective linear filter, effectively reducing the in-band impulsive interference.

In Fig. 3, and in the diagrams of Figs. 4 through 7 that follow, the double lines indicate that the input and/or output signals of the circuit components represented by these lines may be complex and/or vector signals as well as real (scalar) signals, and it is implied that the respective operations (e.g.

filtering and subtraction) are performed on a component-by-component basis. For complex and/or vector signals, the magnitude (absolute value) of the difference signal can be defined as the square root of the sum of the squared components of the difference signal.

IV. INCREASING PEAKEDNESS OF INTERFERENCE TO IMPROVE ITS NDL-BASED MITIGATION

As discussed in Section II, the amplitude distribution of a technogenic signal is generally modifiable by linear filtering. Given a linear filter and an input technogenic signal characterized by some peakedness, the peakedness of the output signal can be smaller, equal, or greater than the peakedness of the input signal, and the relation between the input and the output peakedness may be different for different technogenic signals and/or their mixtures. Such a contrast in the modification of the amplitude distributions of different technogenic signals by linear filtering can be used for separation of these signals by nonlinear filters such as the NDLs introduced in Section III.

For example, let us assume that an interfering signal affects a signal of interest in a passband of interest. Let us further assume that a certain front-end linear filter transforms an interfering sub-Gaussian signal into an impulsive signal, or increases peakedness of an interfering super-Gaussian signal, while the peakedness of the signal of interest remains relatively small. The impulsive interference can then be mitigated by a nonlinear filter such as an NDL. If the front-end linear filter does not affect the passband of interest, the output of the nonlinear filter would contain the signal of interest with improved quality. If the front-end linear filter affects the passband of interest, the output of the nonlinear filter can be further filtered with a linear filter reversing the effect of the front-end linear filter in the signal passband, for example, by a filter canceling the poles and zeros of the front-end filter. As a result, employing appropriate linear filtering preceding an NDL in a signal chain allows effective NDL-based mitigation of technogenic noise even when the latter is not impulsive but sub-Gaussian.

Let us illustrate the above statement using the simulated interference example found in [9].² For the transmitter-receiver pair schematically shown at the top, Fig. 4 provides time (upper panel) and frequency (middle panel) domain quantification, and the average amplitude densities of the in-phase (I) and quadrature (Q) components (lower panel) of the receiver signal without thermal noise after the lowpass filter (green lines), and after the lowpass filter cascaded with a 65 MHz notch filter (black lines). The passband of the receiver signal of interest (baseband) is indicated by the vertical red dashed lines, and thus the signal induced in the receiver by the external transmitter can be viewed as a wide-band non-Gaussian noise affecting a narrower-band baseband signal of interest. In this example, the technogenic noise dominates over the thermal noise.

²The reader is referred to [9] for a detailed description of the interference mechanism, simulation parameters, and the NDL configurations used in the examples of this section.

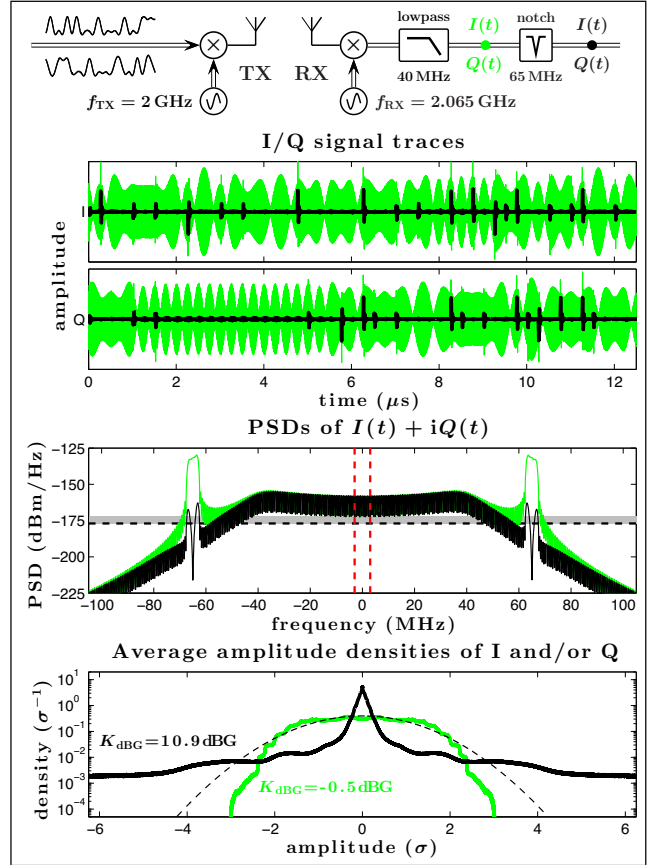

Fig. 4. In-phase/quadrature (I/Q) signal traces (upper panel), PSDs (middle panel), and average amplitude densities of I and Q components (lower panel) of the receiver signal after the lowpass filter (green lines), and after the lowpass filter cascaded with a 65 MHz notch filter (black lines). In the middle panel, the thermal noise density is indicated by the horizontal dashed line, and the width of the shaded band indicates the receiver noise figure (5 dB). In the lower panel, σ is the standard deviation of a respective signal (I and/or Q), and the Gaussian amplitude density is shown by the dashed line.

The interference in the nominal $\pm 40 \text{ MHz}$ passband of the receiver lowpass filter is due to the non-zero end values of the finite impulse response filters used for pulse shaping of the transmitter modulating signal, and is impulsive due to the mechanism described in [7], [8]. However, the response of the receiver 40 MHz lowpass filter at 65 MHz is relatively large, and, as can be seen in all panels of Fig. 4 (green lines and text), the contribution of the transmitter signal in its nominal band becomes significant, reducing the peakedness of the total interference and making it sub-Gaussian (-0.5 dBG peakedness). Since the sub-Gaussian part of the interference lies outside of the baseband, cascading a 65 MHz notch filter with the lowpass filter reduces this part of the interference without affecting either the signal of interest or the power spectral density (PSD) of the impulsive interference around the baseband. Then, as shown by the black lines and text in Fig. 4, the interference becomes super-Gaussian (10.8 dBG peakedness), enabling its effective mitigation by the NDLs.

Figure 5 shows the SNRs in the receiver baseband as functions of the NDL resolution parameter α for an incoming

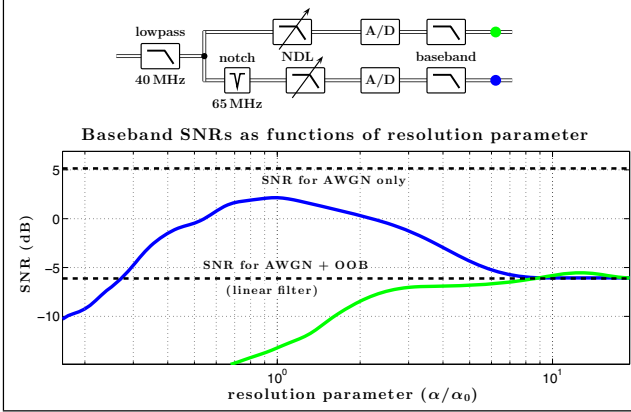

Fig. 5. SNRs in the receiver baseband as functions of the NDL resolution parameter α when the NDL is applied directly to the signal+noise mixture (green line), and when a 65 MHz notch filter precedes the NDL (blue line).

“native” (in-band) receiver signal affected, in addition to the additive white Gaussian noise (AWGN), by the interference shown in Fig. 4. The green line shows the baseband SNR when the NDL is applied directly to the output of the 40 MHz lowpass filter, and the blue line – when a 65 MHz notch filter precedes the NDL. As can be seen in Fig. 5 from the distance between the horizontal dashed lines, when linear processing is used (NDL with $\alpha \rightarrow \infty$, or no NDL at all), the interference reduces the SNR by approximately 11 dB. When an NDL is deployed immediately after the 40 MHz lowpass filter, it will not be effective in suppressing the interference (green line). However, a 65 MHz notch filter preceding the NDL attenuates the non-impulsive part of the interference without affecting either the signal of interest or the PSD of the impulsive interference, making the interference impulsive and enabling its effective mitigation by the subsequent NDL (blue line). In this example, the NDL with $\alpha = \alpha_0$ improves the SNR by approximately 8.2 dB, suppressing the interference from the transmitter by approximately a factor of 6.6. If the Shannon formula [23] is used to calculate the capacity of a communication channel, the baseband SNR increase from -6 dB to 2.2 dB provided by the NDL in the example of Fig. 5 results in a factor of 4.37 increase in the channel capacity.

V. ADAPTIVE NDLS FOR NON-STATIONARY SIGNALS AND/OR TIME-VARYING NOISE CONDITIONS

The range of linear behavior of an NDL is determined and/or controlled by the resolution parameter α . A typical use of an NDL for mitigation of impulsive technogenic noise requires that the NDL’s response remains linear while the input signal is the signal of interest affected by the Gaussian (non-impulsive) component of the noise, and that the response becomes nonlinear only when a higher magnitude outlier is encountered. When the properties of the signal of interest and/or the noise vary significantly with time, a constant resolution parameter may not satisfy this requirement.

For example, the properties of such non-stationary signal as a speech signal typically vary significantly in time, as the frequency content and the amplitude/power of the signal

change from phoneme to phoneme. Even if the impulsive noise affecting a speech signal is stationary, its effective mitigation may require that the resolution parameter of the NDL varies with time.

For instance, for effective impulsive noise suppression throughout the speech signal the resolution parameter α should be set to a small value during the “quiet” periods of the speech (no sound), and to a larger value during the high amplitude and/or frequency phonemes (e.g. consonants, especially plosive and fricative). Such adaptation of the resolution parameter α to changing input conditions can be achieved through monitoring the tendency of the magnitude of the difference signal, for example, in a moving window of time.

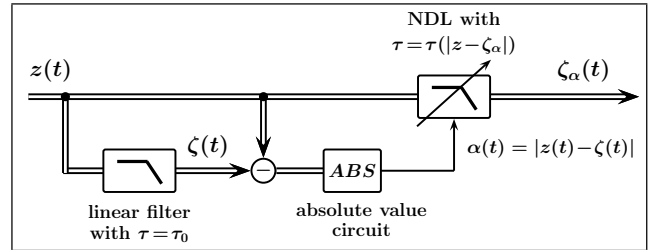

Fig. 6. NDL filtering arrangement equivalent to linear filter.

In order to convey the subsequent examples more clearly, let us first consider the filtering arrangement shown in Fig. 6. In this example, the NDL is of the same type and order as the linear filter, and only the time parameter τ of the NDL is a function of the difference signal, $\tau = \tau(|z - \zeta_\alpha|)$. It should be easily seen that, if the NDL time parameter is given by equation (4), then $\zeta_\alpha(t) = \zeta(t)$ and thus the resulting filter is equivalent to the linear filter.

Let us now modify the circuit shown in Fig. 6 in a manner illustrated in Fig. 7, where a Windowed Measure of Tendency (WMT) circuit is applied to the absolute value of the difference signal of the linear filter $|z(t) - \zeta(t)|$, providing a measure of a magnitude of this difference signal in a moving time window.

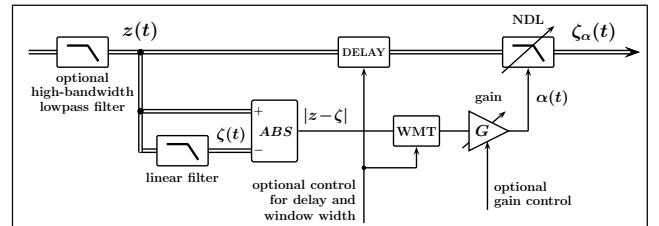

Fig. 7. Conceptual block diagram of ANDL.

Let us first assume a zero group delay of the WMT circuit. If the effective width of the moving window is comparable with the typical duration of an outlier in the input signal, or larger than the outliers duration, then the attenuation of the outliers in the magnitude of the difference signal $|z(t) - \zeta(t)|$ by the WMT circuit will be greater in comparison with the attenuation of the portions of $|z(t) - \zeta(t)|$ not containing such outliers. By applying an appropriately chosen gain $G > 1$

to the output of the WMT circuit, the gained WMT output can be made larger than the magnitude of the difference signal $|z(t) - \zeta(t)|$ when the latter does not contain outliers, and smaller than $|z(t) - \zeta(t)|$ otherwise. As the result, if the gained WMT output is used as the NDL's resolution parameter, the NDL's response will become nonlinear only when an outlier is encountered.

Since a practical WMT circuit would employ a causal moving window with non-zero group delay, the input to the NDL circuit needs to be delayed to compensate for the delay introduced by the WMT circuit. Such compensation can be accomplished by, for example, an appropriately chosen delay or all-pass filter. When an all-pass filter is used for the delay compensation, as indicated in Fig. 7, a high-bandwidth lowpass filter may need to be used as a front end of an ANDL to improve the signal shape preservation by the all-pass filter. The delay and/or all-pass filters can be implemented using the approaches and the circuit topologies described, for example, in [24]–[28]. Since the group delay of a WMT circuit generally relates to the width of its moving window, any change in this width would require an appropriate change in the delay, as indicated in Fig. 7.

It should be easily seen that in the limit of a large gain, $G \rightarrow \infty$, an ANDL becomes equivalent to the respective linear filter with $\tau = \tau_0 = \text{const}$. When the noise affecting the signal of interest contains impulsive outliers, however, the signal quality will exhibit a global maximum at a certain finite value of the gain parameter $G = G_{\text{max}}$, providing the qualitative behavior of an ANDL illustrated in Fig. 8.

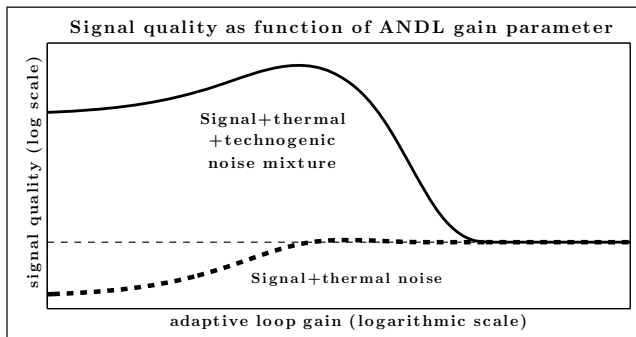

Fig. 8. Improving signal quality by ANDL.

As indicated by the horizontal dashed line in the figure, as long as the noise retains the same power and spectral composition, the signal quality of the output of a linear filter remains unchanged regardless the proportion of the thermal and the technogenic (e.g. impulsive) components in the noise mixture. In the limit of a large gain parameter, an ANDL is equivalent to the respective linear filter with $\tau = \tau_0 = \text{const}$, resulting in the same signal quality of the filtered output as provided by the linear filter, whether the noise contains an impulsive component (solid curve) or it is purely thermal (dashed curve). If viewed as a function of the gain, however, when the noise contains an impulsive component the signal quality of the ANDL output exhibits a global maximum, and

the larger the fraction of the impulsive noise in the mixture, the more pronounced is the maximum in the signal quality. This property of an ANDL enables its use for improving the signal quality in excess of that achievable by the respective linear filter, effectively reducing the in-band impulsive interference.

VI. EXAMPLES OF ANDL PERFORMANCE

To provide examples demonstrating ANDL performance, let us consider a non-stationary signal of interest (a fragment of a speech signal shown in the upper panel of Fig. 9) affected by impulsive noise. To enhance the visual clarity of the examples, the noise is a simplified white impulsive noise consisting of short-duration pulses of random polarity and arrival times, and of approximately equal heights. The signal of interest affected by the impulsive noise is shown in the lower panel of Fig. 9, and the initial SNR is -0.2 dB, as indicated in the upper right corner of the panel. The specific time intervals I and II are indicated by the vertical dashed lines and correspond to a fricative consonant and a vowel, respectively.

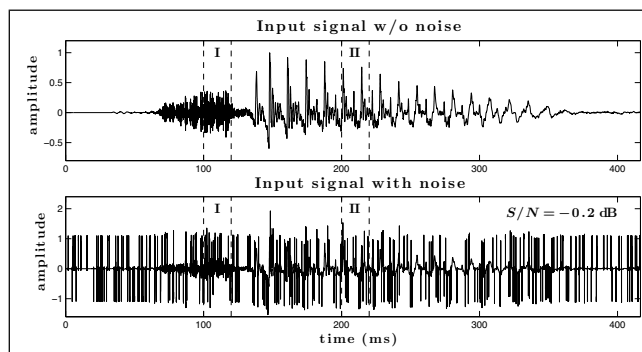

Fig. 9. Fragment of speech signal without noise (top) and affected by impulsive noise (bottom).

Given the input signal+noise mixture shown in the lower panel of Fig. 9, Fig. 10 shows the delayed output of the absolute value circuit (black lines), and the gained output $\alpha(t)$ of the WMT circuits (red lines), for the time intervals I and II, respectively. For reference, the input noise pulses are indicated below the respective panels. One can see that the portions of the output of the absolute value circuit corresponding to the impulsive noise extend above the “envelope” $\alpha(t)$, while the rest of the output generally remains below $\alpha(t)$.

Fig. 11 shows the value of the time parameter τ of the NDL as a function of time when the resolution parameter α in (4) is the gained output of the WMT circuit $\alpha = \alpha(t)$, for the time intervals I and II, respectively. One can see that the time parameter significantly increases when an outlier in the difference signal – corresponding to a noise pulse – is encountered. Such an increase in the time parameter of the NDL will result in a better suppression of the impulsive noise by an ANDL in comparison with the respective linear filter with a constant time parameter $\tau = \tau_0$.

In Fig. 12, the output of such a linear filter is shown by the red lines. For comparison, the output of the linear filter for an input signal without noise is superimposed on top of the noisy

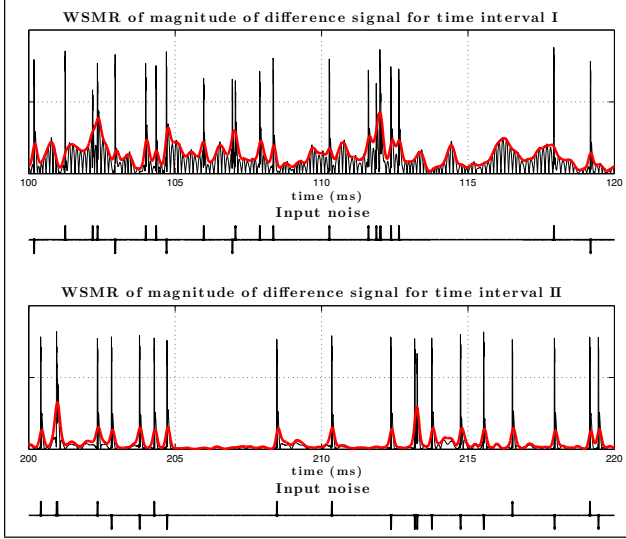

Fig. 10. WMT of magnitude of difference signal (red line) for time intervals I (upper panel) and II (lower panel) indicated in Fig. 9. WMT is obtained by Windowed Squared Mean Root (WSMR) circuit shown in Fig. 18.

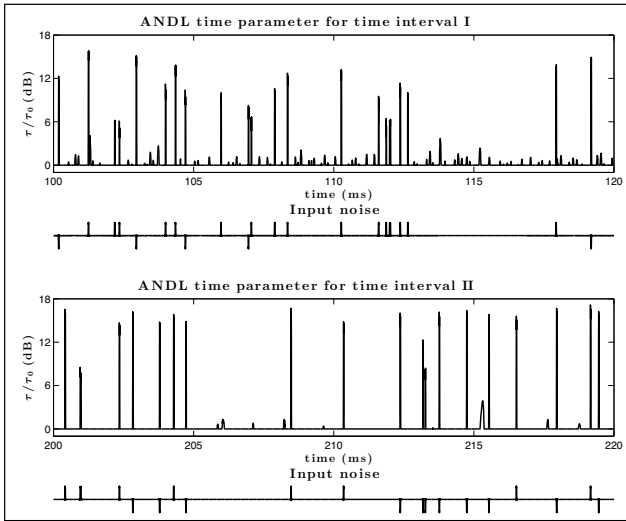

Fig. 11. ANDL time parameter for time intervals I (upper panel) and II (lower panel) indicated in Fig. 9.

output, and is shown by the black lines. Further, the output of the ANDL is superimposed on top of the noisy and noiseless outputs of the linear filter, and is shown by the green lines. One should be able to see from Fig. 12 that the ANDL indeed effectively suppresses the impulsive noise without distorting the shape of the signal of interest, and that the ANDL output closely corresponds to the output of the linear filter for an input signal without noise.

Fig. 13 provides an overall comparison of the noisy input signal and the outputs of the linear and the ANDL filters. The signal-to-noise ratios for the incoming and the filtered signals are shown in the upper right corners of the respective panels. One can see that, in this example, the ANDL significantly improves the signal quality (over 20 dB increase in the SNR

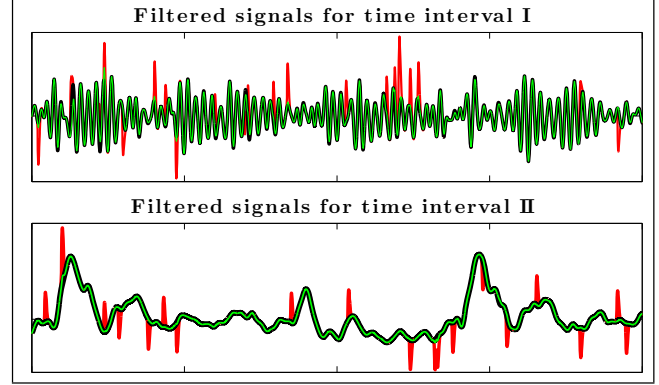

Fig. 12. Comparison of linear and ANDL outputs for time intervals I (left) and II (right) indicated in Fig. 13.

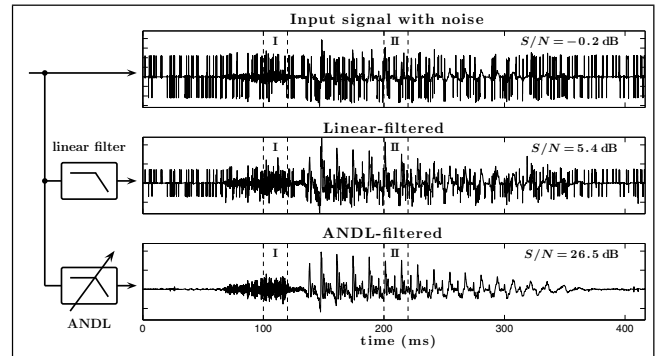

Fig. 13. Comparison of input and linear/ANDL outputs for speech signal affected by impulsive noise.

in comparison with the linear filter), and is suitable for filtering such highly non-stationary signals as speech signals.

Figs. 14 and 15 quantify the improvements in the signal quality by the ANDL used in the previous examples when the total noise is a mixture of the impulsive and thermal noises. Fig. 14 shows the total SNR as a function of the ANDL gain G for different fractions of the impulsive noise in the mixture (from 0 to 100%), and should be compared with Fig. 8. In Fig. 14, G_0 denotes the value of gain for which maximum SNR is achieved for 100% impulsive noise. Further, Fig. 15 shows the power spectral densities (PSDs) of the filtered signal of interest (blue line), the residual noise of the linear filter (dashed red line), and the PSDs of the residual noise of the ANDL-filtered signals, for the gain value G_0 and different fractions of the impulsive noise (black lines).

VII. EXAMPLES OF ANDL SUB-CIRCUIT TOPOLOGIES

This section outlines brief examples of idealized algorithmic topologies for several ANDL sub-circuits based on the operational transconductance amplifiers (OTAs). Transconductance cells based on the metal-oxide-semiconductor (MOS) technology represent an attractive technological platform for implementation of such active nonlinear filters as ANDLs, and for their incorporation into IC-based signal processing systems. ANDLs based on transconductance cells offer simple and predictable design, easy incorporation into ICs based on

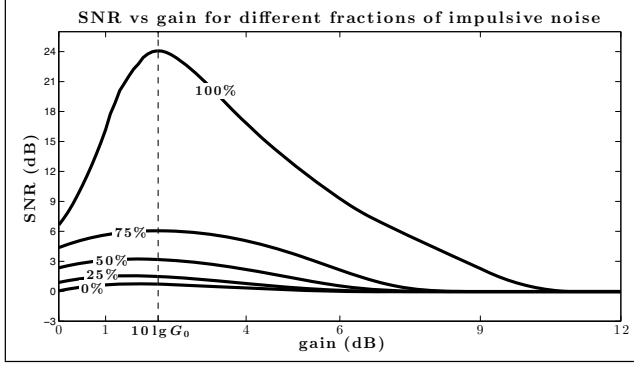

Fig. 14. SNR vs. gain for different thermal and impulsive noise mixtures.

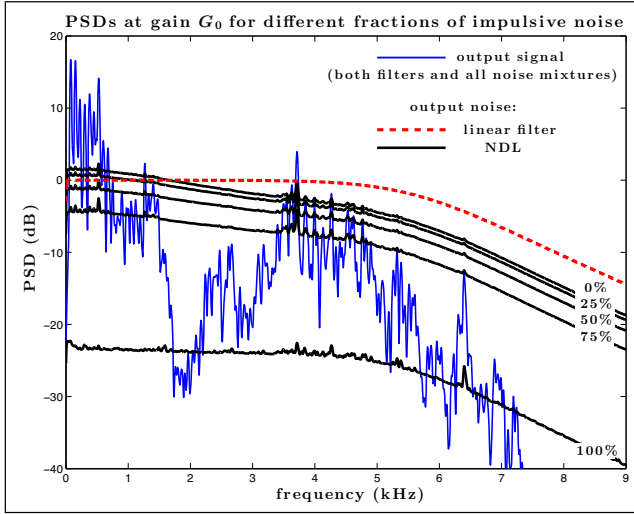

Fig. 15. PSDs at gain G_0 for different thermal and impulsive noise mixtures.

the dominant IC technologies, small size, and can be used from the low audio range to gigahertz applications [25], [27], [29], [30].

Fig. 16 provides an example of a conceptual schematic of a voltage-controlled second order lowpass filter with Tow-Thomas topology [29], [30]. The quality factor of this filter is $Q = \sqrt{\gamma}$, and, if the transconductance g_m of the OTAs is proportional to the control voltage V_c , $g_m = \beta V_c$, then the time parameter in (3) is $\tau = \frac{C}{\beta V_c}$.

An example of a control voltage circuit is shown in Fig. 17. When the output V_c of this circuit is used to control the time parameter of the circuit shown in Fig. 16, the time parameter will be described by (4).

Fig. 18 provides an example of a conceptual schematic of a windowed measure of tendency (WMT) circuit supplying the resolution parameter $\alpha = \alpha(t)$ to the control voltage circuit of the NDL shown in Fig. 17. In this example, the WMT is obtained as a Windowed Squared Mean Root (WSMR). After the gain G , the resolution parameter $\alpha = \alpha(t)$ supplied by the WSMR circuit to the NDL will be

$$\alpha(t) = G \left\{ w(t) * |z(t) - \zeta(t)|^{\frac{1}{2}} \right\}^2, \quad (5)$$

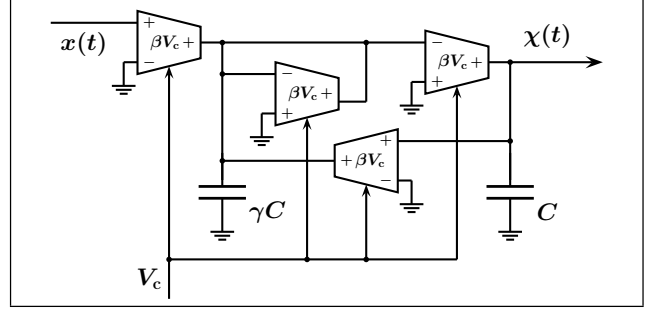

Fig. 16. Voltage-controlled 2nd order lowpass filter with Tow-Thomas topology.

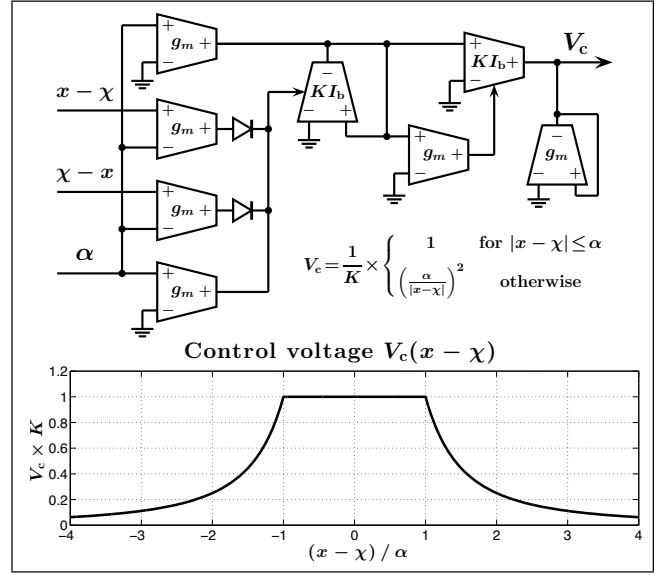

Fig. 17. NDL control voltage circuit.

which is more robust to the outliers in the magnitude of the difference signal $|z(t) - \zeta(t)|$ than a simple windowed averaging providing the resolution parameter $\alpha(t) = G w(t) * |z(t) - \zeta(t)|$.

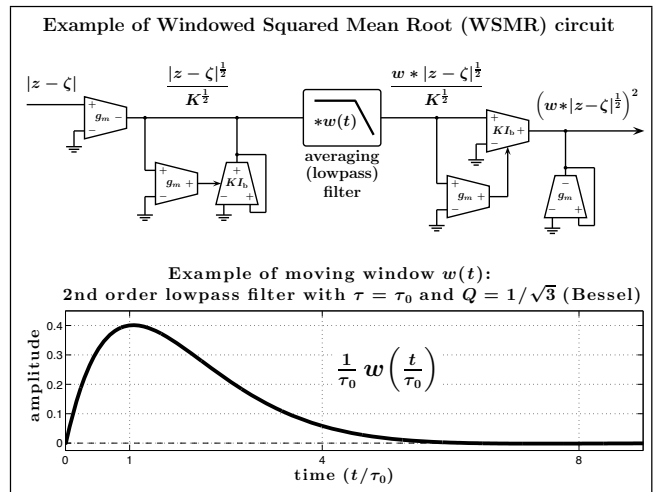

Fig. 18. Example of WMT circuit.

The remaining sub-circuits of the ANDL circuit described in this paper are the absolute value (ABS) circuit (rectifier), and the delay (all-pass) sub-circuit. These sub-circuits can be implemented using the approaches and the circuit topologies described, for example, in [31]–[33] and [24]–[28], respectively.

VIII. CONCLUSION

In this paper, we introduce algorithms and conceptual circuits for particular nonlinear filters, NDLs and ANDLs, and outline a methodology for their use to mitigate in-band noise and interference, especially that of technogenic (man-made) origin. In many instances, these filters can improve the signal quality in the presence of technogenic interference in excess of that achievable by the respective linear filters. NDLs/ANDLs are designed to be fully compatible with existing linear devices and systems, and to be used as an enhancement, or as a low-cost alternative, to the state-of-art interference mitigation methods.

ACKNOWLEDGMENT

The authors would like to thank Jeffrey E. Smith of BAE Systems for his valuable suggestions and critical comments.

REFERENCES

- [1] F. Leferink, F. Silva, J. Catrysse, S. Batterman, V. Beauvois, and A. Roc'h, "Man-made noise in our living environments," *Radio Science Bulletin*, no. 334, pp. 49–57, September 2010.
- [2] J. D. Parsons, *The Mobile Radio Propagation Channel*, 2nd ed. Chichester: Wiley, 2000.
- [3] K. Slattery and H. Skinner, *Platform Interference in Wireless Systems*. Elsevier, 2008.
- [4] A. V. Nikitin, M. Epard, J. B. Lancaster, R. L. Lutes, and E. A. Shumaker, "Impulsive interference in communication channels and its mitigation by SPART and other nonlinear filters," *EURASIP Journal on Advances in Signal Processing*, vol. 2012, no. 79, 2012.
- [5] X. Yang and A. P. Petropulu, "Co-channel interference modeling and analysis in a Poisson field of interferers in wireless communications," *IEEE Transactions on Signal Processing*, vol. 51, no. 1, pp. 64–76, 2003.
- [6] A. Chopra, "Modeling and mitigation of interference in wireless receivers with multiple antennae," PhD thesis, The University of Texas at Austin, December 2011.
- [7] A. V. Nikitin, "On the impulsive nature of interchannel interference in digital communication systems," in *Proc. IEEE Radio and Wireless Symposium*, Phoenix, AZ, 2011, pp. 118–121.
- [8] —, "On the interchannel interference in digital communication systems, its impulsive nature, and its mitigation," *EURASIP Journal on Advances in Signal Processing*, vol. 2011, no. 137, 2011.
- [9] A. V. Nikitin, R. L. Davidchack, and J. E. Smith, "Out-of-band and adjacent-channel interference reduction by analog nonlinear filters," in *Proceedings of 3rd IMA Conference on Mathematics in Defence*, Malvern, UK, Oct. 2013.
- [10] I. Shanthi and M. L. Valarmathi, "Speckle noise suppression of SAR image using hybrid order statistics filters," *International Journal of Advanced Engineering Sciences and Technologies (IJAEST)*, vol. 5, no. 2, pp. 229–235, 2011.
- [11] R. Dragomir, S. Puscoci, and D. Dragomir, "A synthetic impulse noise environment for DSL access networks," in *Proceedings of the 2nd International conference on Circuits, Systems, Control, Signals (CSCS'11)*, 2011, pp. 116–119.
- [12] V. Guillet, G. Lamarque, P. Ravier, and C. Léger, "Improving the power line communication signal-to-noise ratio during a resistive load commutation," *Journal of Communications*, vol. 4, no. 2, pp. 126–132, 2009.
- [13] S. A. Bhatti, Q. Shan, R. Atkinson, M. Vieira, and I. A. Glover, "Vulnerability of Zigbee to impulsive noise in electricity substations," in *General Assembly and Scientific Symposium, 2011 XXXth URSI*, 13–20 Aug. 2011.
- [14] S. R. Mallipeddy and R. S. Kshetrimayum, "Impact of UWB interference on IEEE 802.11a WLAN system," in *National Conference on Communications (NCC)*, 2010.
- [15] C. Fischer, "Analysis of cellular CDMA systems under UWB interference," in *International Zurich Seminar on Communications*, 2006, pp. 130–133.
- [16] A. V. Nikitin, "Method and apparatus for signal filtering and for improving properties of electronic devices," US patent 8,489,666, 16 July 2013.
- [17] —, "Method and apparatus for signal filtering and for improving properties of electronic devices," US patent application 13/715,724, filed 14 Dec. 2012.
- [18] E. M. Royer and C.-K. Toh, "A review of current routing protocols for ad-hoc mobile wireless networks," *IEEE Personal Communications*, vol. 6, no. 2, pp. 46–55, Apr. 1999.
- [19] M. Abramowitz and I. A. Stegun, Eds., *Handbook of Mathematical Functions with Formulas, Graphs, and Mathematical Tables*, ser. 9th printing. New York: Dover, 1972.
- [20] A. Hyvärinen, J. Karhunen, and E. Oja, *Independent component analysis*. New York: Wiley, 2001.
- [21] R. Bracewell, *The Fourier Transform and Its Applications*, 3rd ed. New York: McGraw-Hill, 2000, ch. "Heaviside's Unit Step Function, $H(x)$ ", pp. 61–65.
- [22] P. A. M. Dirac, *The Principles of Quantum Mechanics*, 4th ed. London: Oxford University Press, 1958.
- [23] C. E. Shannon, "Communication in the presence of noise," *Proc. Institute of Radio Engineers*, vol. 37, no. 1, pp. 10–21, Jan. 1949.
- [24] K. Bult and H. Wallinga, "A CMOS analog continuous-time delay line with adaptive delay-time control," *IEEE Journal of Solid-State Circuits (JCSS)*, vol. 23, no. 3, pp. 759–766, 1988.
- [25] R. Schaumann and M. E. Van Valkenburg, *Design of analog filters*. Oxford University Press, 2001.
- [26] A. Díaz-Sánchez, J. Ramírez-Angulo, A. Lopez-Martin, and E. Sánchez-Sinencio, "A fully parallel CMOS analog median filter," *IEEE Transactions on Circuits and Systems II: Express Briefs*, vol. 51, no. 3, pp. 116–123, 2004.
- [27] Y. Zheng, "Operational transconductance amplifiers for gigahertz applications," PhD thesis, Queen's University, Kingston, Ontario, Canada, September 2008.
- [28] A. U. Keskin, K. Pal, and E. Hancioglu, "Resistorless first-order all-pass filter with electronic tuning," *Int. J. Electron. Commun. (AEÜ)*, vol. 62, pp. 304–306, 2008.
- [29] Y. Sun, *Design of High Frequency Integrated Analogue Filters*, ser. IEE Circuits, Devices and Systems Series, 14. The Institution of Engineering and Technology, 2002.
- [30] T. Parveen, *A Textbook of Operational transconductance Amplifier and Analog Integrated Circuits*. I.K. International Publishing House Pvt. Ltd., 2009.
- [31] E. Sánchez-Sinencio, J. Ramírez-Angulo, B. Linares-Barranco, and A. Rodríguez-Vázquez, "Operational transconductance amplifier-based nonlinear function syntheses," *IEEE Journal of Solid-State Circuits (JCSS)*, vol. 24, no. 6, pp. 1576–1586, 1989.
- [32] N. Minhaj, "OTA-based non-inverting and inverting precision full-wave rectifier circuits without diodes," *International Journal of Recent Trends in Engineering*, vol. 1, no. 3, pp. 72–75, 2009.
- [33] C. Chanapromma, T. Worachak, and P. Silapan, "A temperature-insensitive wide-dynamic range positive/negative full-wave rectifier based on operational transconductance amplifier using commercially available ICs," *World Academy of Science, Engineering and Technology*, vol. 58, pp. 49–52, 2011.